

ODP 333

::: Receipt Printer User's Manual :::

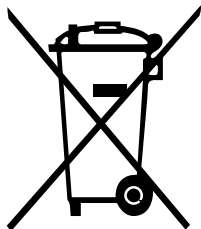

All specifications are subject to change without notice



Disposal of Old Electrical & Electronic Equipment (Applicable in the European Union and other European countries with separate collection systems)

This symbol on the product or on its packaging indicates that this product shall not be treated as household waste. Instead it shall be handed over to the applicable collection point for the recycling of electrical and electronic equipment.

For more detailed information about recycling of this product, please contact your local city office, your household waste disposal service or the shop where you purchased the product.



TABLE OF CONTENTS

1. Parts Identifications	4
2. Setting up the printer	
2.1 Unpacking	5
2.2 Connecting the cables	6
2.3 Loading the roll paper	9
3. Control panel and other functions	
3.1 Control panel	12
3.2 Error Indicating	12
4. Self Test	13
5. Hexadecimal Dump	13
6. Select Baudrate Mode	14
7. Hexadecimal Dump	14
8. Printer cleaning	15
9. Specifications	
9.1. General Specifications	16
9.2. Auto Cutter Specifications	18
9.3. Interface	18
9.4. Electrical Characteristics	18
9.5. Environmental Requirements	19
9.6. Reliability	19
9.7. Certification	19
10. Command List	20

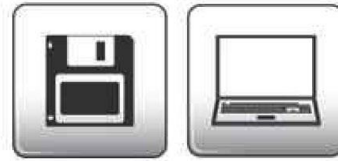

FR

Le Groupe AURES vous remercie de votre confiance.

Téléchargez nos derniers drivers et utilitaires ainsi que nos conseils d'installation sur le site du Support Technique AURES :

www.ares-support.fr

UK

The AURES Group thanks you for your loyalty.

To download our most recent drivers and utilities- and obtain advice regarding the installation of your equipment, please visit the AURES Technical Support Website:

www.ares-support.fr/UK

DE

Die AURES Gruppe bedankt sich für Ihre Bestellung.

Um unserneuesten Treiber, Utilities und Konfigurationsratschläge zu Ihren Produkten herunterzuladen besuchen Sie bitte unsere technische Support- Website:

www.ares-support.fr/GE

1. Parts Identifications

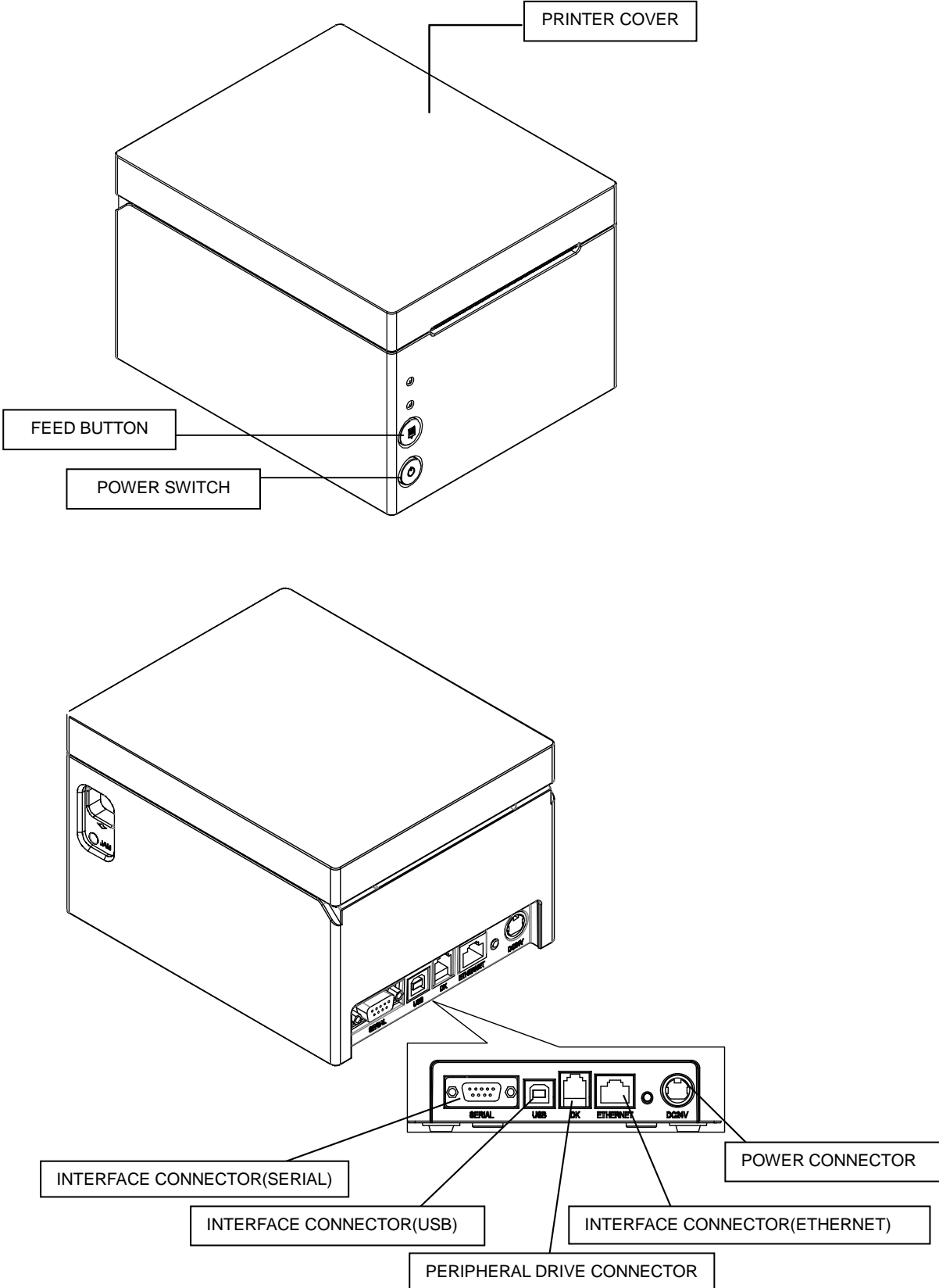

2. Setting Up the Printer

2-1. Unpacking

Your printer box should include following items. If any of the following items are damaged or missing, please contact your dealer for assistance.

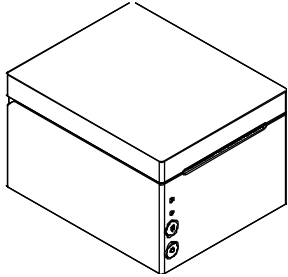

Printer

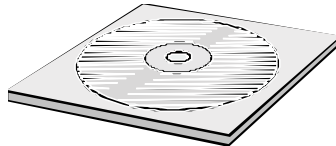

CD
(Drivers and Documentation)

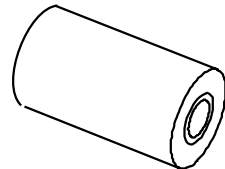

Paper

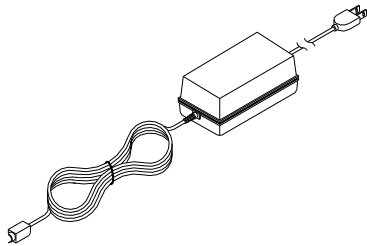

Adaptor (Option)

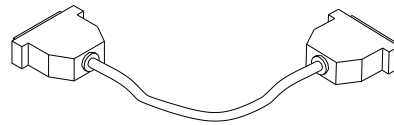

Interface Cable (Option)

2-2. Connecting the Cables

In order to use the printer, you are required to connect cables to the printer. All cables connect to the connector panel on the rear side of the printer, which is shown below:

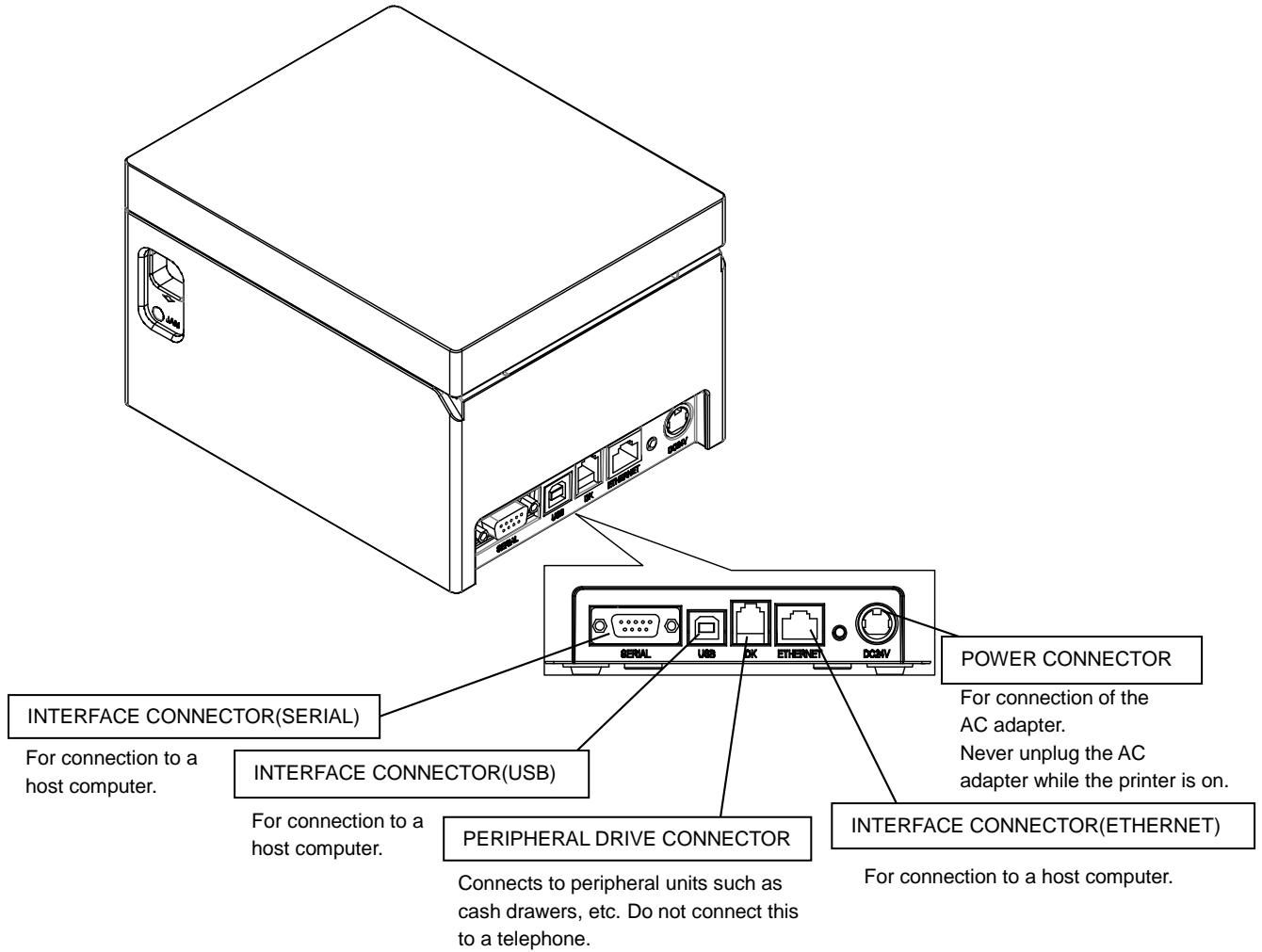

Before connecting any of the cables, make sure that both the printer and the computer are turned off.

2-2-1. Interface Connector

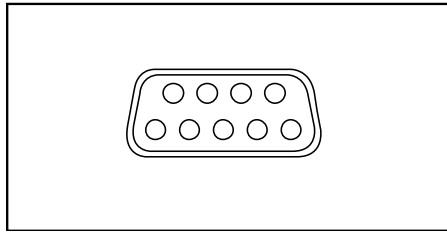

<9 Pin Serial>

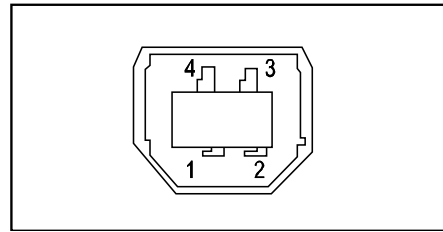

<USB "B" Type>

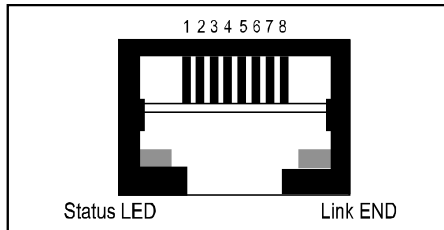

<Ethernet>

- USB interface

PIN	SIGNAL	I/O	DESCRIPTION
1	+5V	-	+5V
2	DATA-	-	Printer transmit data line
3	DATA+	-	Printer transmit data line
4	GND	-	System Ground

- 9Pin Serial Interface

PIN	SIGNAL	I/O	DESCRIPTION
2	RXD	Input	Printer receive data line RS-232C level
3	TXD	Output	Printer transmit data line RS-232C level
4,7	DTR	Output	Printer handshake to host line RS-232C level
5	GND	-	System Ground
6	DSR	Input	Data Send Ready
1,8,9	NC		

Ethernet Interface

PIN	SIGNAL	I/O
1	Data Out +	Output Data +
2	Data Out -	Output Data -
3	GND	Ground
4	Data IN +	Input Data +
5	Data IN -	Input Data -
6	N.C	
7	N.C	
8	N.C	

2-2-2. Cash Drawer Connector

The printer can operate two cash drawers with a 6 pin RJ-11 modular connector. The driver is capable of supplying a maximum current of 1.0A for 510ms or less when the printer is not printing.

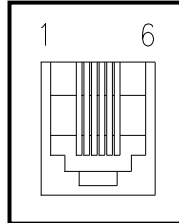

PIN	SIGNAL	DESCRIPTION
1	Signal GND	-
2	Drawer kick-out drive signal 1	Output
3	Drawer open/close signal	Input
4	+24V	-
5	Drawer kick-out drive signal 2	Output
6	Signal GND	-

2-3. Loading the Roll Paper

Notes: Be sure to use paper rolls that meet the specifications. Do not use paper rolls that have the paper glued to the core because the printer cannot detect the paper end correctly. (Turn off power switch)

☞ Turn off power switch.

1. Make sure that the printer is not receiving data; otherwise, data may be lost.
2. Open the top cover by pushing down the cover-open button.

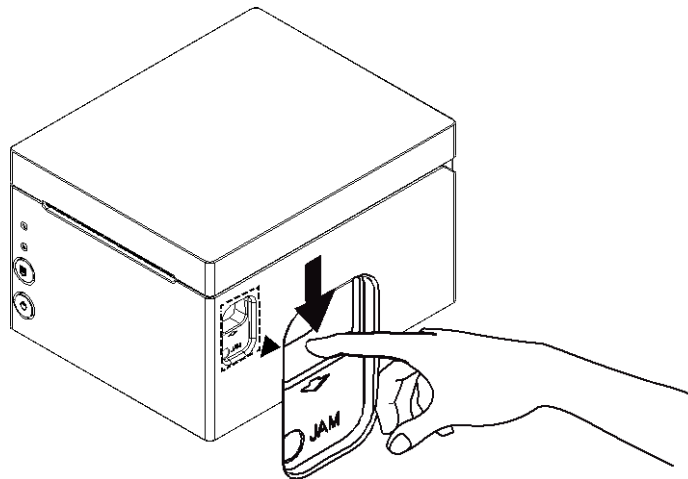

3. Remove the used paper roll core if there is one inside.
4. Insert new paper roll as shown.

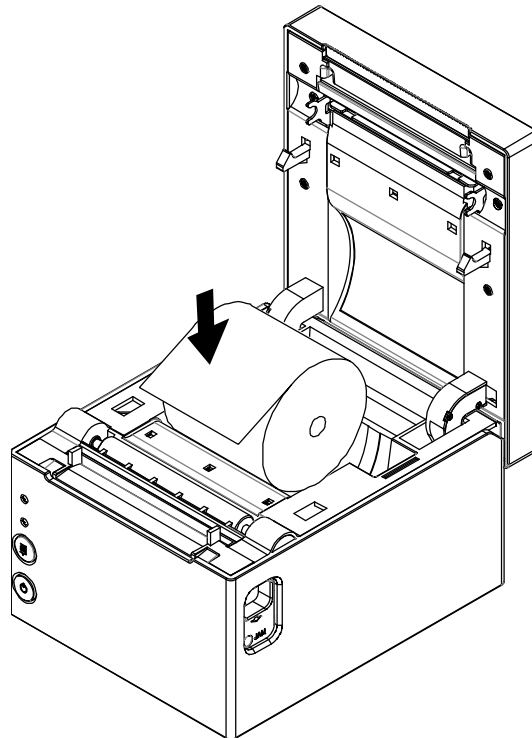

5. Note the correct direction of how paper comes off the roll.

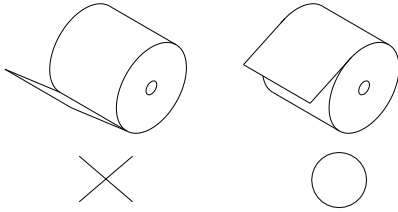

6. Pull out a small portion of paper, as shown. Then, close the cover.

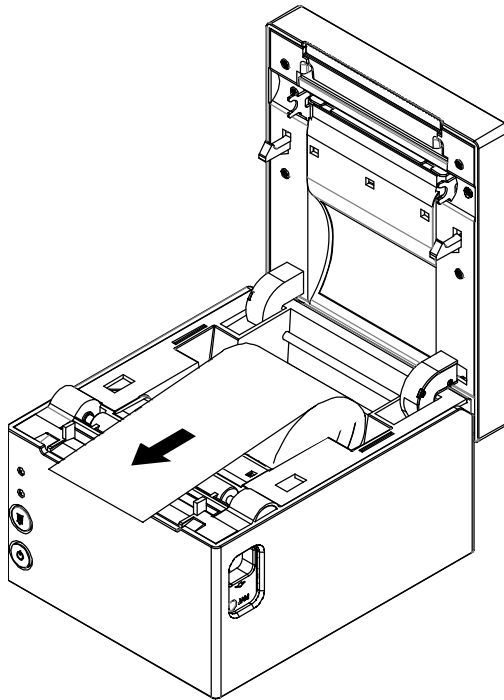

7. Tear off the paper as shown.

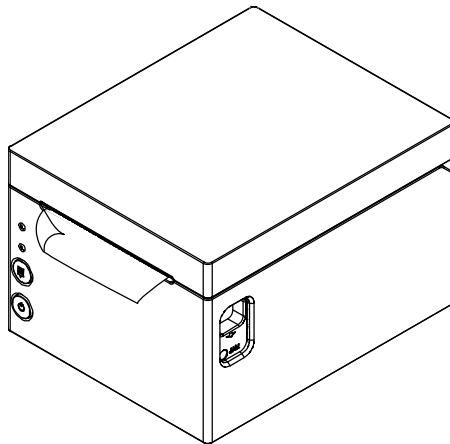

 **CAUTION:**

When the paper is jammed from cutter, the top cover might be stuck as well. In this case, repeat power on and off several times.

If the top cover is still stuck, please follow the steps to release the papers from jamming.

1. Make sure the printer is turned off.
2. Plug in the screw driver into the hole next to where it says “JAM” on the cover-open button. Then turn screw with drivers to a direction until paper is released from the cutter.

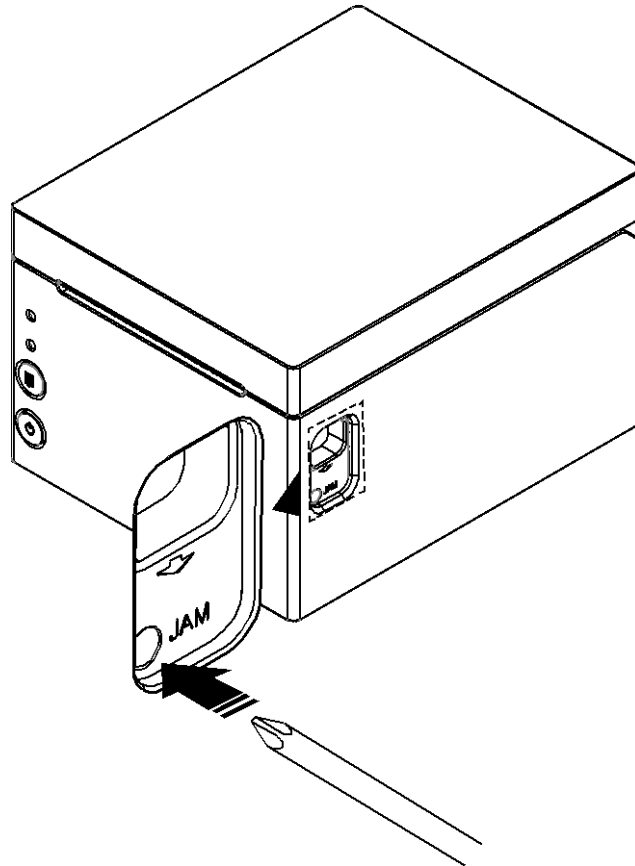

3. Control panel and other functions.

3-1. Control panel

You can control the basic paper feeding operations of the printer with the button on the control panel. The indicator lights help you to monitor the printer's status.

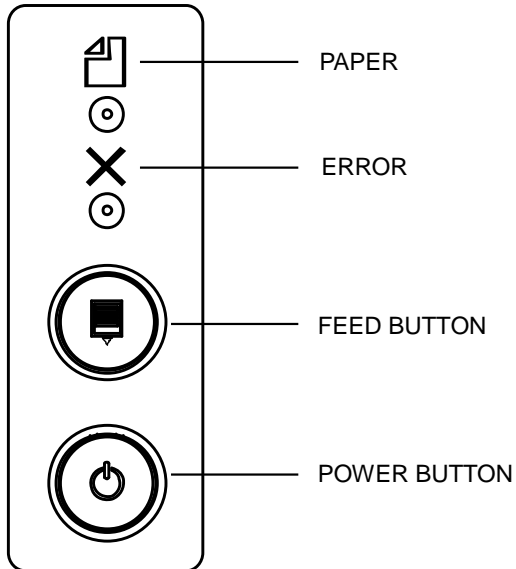

Button

The button can be disabled by the ESC c 5 command.

Press the FEED button once to advance paper one line. You can also hold down the FEED button to feed paper continuously.

3-2. Error indicating

This section explains the different patterns signaled by the two LED indicators located on the top cover of the printer.

STATUS	PAPER	ERROR	POWER	REMARKS
	RED	RED	GREEN	
Power off	OFF	OFF	OFF	Normal power is not supplied to the printer
Power on	OFF	OFF	ON	Normal power is supplied to the printer
On line	OFF	OFF	ON	Normal error-free mode
Cover open	OFF	ON	ON	Close cover
Paper empty	OFF	ON	ON	Insert new paper roll
Paper near end	ON	OFF	ON	Paper is low
Test mode	OFF	OFF	ON	Ignored error led

4. Self Test

The self-test result indicated whether the printer is operating properly. Also with this, user can check following options or status of the printer.

- Control circuit
- Printer mechanism
- Printing quality
- ROM version
- Interface setting

This test is independent of any other equipment or software.

Running the self test

1. Make sure the printer is turned off and the printer cover is closed properly before performing the self test
2. Turn the printer on holding the FEED button, then the self-test will start. The self-test prints the printer setting value and then prints the following, and pauses. (Error LED On)

SELECT MODE BY BUTTON
1. ASCII PRINT
2. SELECT BAUDRATE MODE
3. HEXADUMP MODE

3. Press the FEED button consecutively (1~3)

1. ASCII PRINT (press the FEED button once)	2.SELECT BAUDRATE MODE (press the FEED button twice)	3. HEXADUMP MODE (press the FEED button triple time)
Printing test page constructed with ASCII code.	Set the speed of Serial Interface (You can set the BAUDRATE in this mode)	Printing the HEX value received from the interface

※ Wait for 5~6 seconds if you want to exit. Printer performs a cutting when exiting this mode

4. The printer is ready to receive data after finishing setting.

5. ASCII Print

ASCII PRINT is printing a test page constructed ASCII code. You can able to check the printer works properly with this

The ASCII PRINT test automatically ends and cuts the paper after printing the following:

***** Completed *****

The printer is ready to receive data as soon as it completes the ASCII PRINT.

6. Select Baudrate Mode

After entering the BAUDRATE MODE, the list which can select the BPS will be printed. Similar like Self Test, you can press the FEED button to select a BAUDRATE.

Once the input performs properly, the printer shows a result and store.

The printer is ready to receive data as soon as it completes the SELECT BAUDRATEMODE.

SELECT BAUDRATE BY BUTTON

1. 9600bps
2. 19200bps
3. 38400bps
4. 115200bps

7. Hexadecimal Dump

This feature allows experienced users to see exactly what data is coming to the printer. This can be useful in finding software problems.

When you go into the hex dump function, the printer prints all commands and other data in hexadecimal format along with a guide section to help you find specific commands.

To use the hex dump feature, follow these steps

1. Please turn printer off.
2. Please turn printer on while press down "Feed" button.
3. Press the FEED button three times when the Self Test printed.
4. Now printer had entered into Hexa dump mode.
5. Run any software program that sends data to the printer. The printer prints "Hexadecimal printing mode..." and then all the codes it receives in a two-column format. The first column contains the hexadecimal codes and the second column gives the ASCII characters that correspond to the codes.

Hexadecimal Dump

```
1B 21 00 1B 26 02 40 40  !.& . @ @  
1B 25 01 1B 63 34 00 1B  .%..c4 ..  
41 42 43 44 45 46 47 48  ABCDEFGH
```

A period (.) is printed for each code that has no ASCII equivalent.

6. Turn off the printer.
7. Turn on the printer.

8. Printer cleaning

If the interior of the printer is dusty, printing quality can be lowered. In such a case, follow the instructions below to clean up the printer.

♣Note :

1. Make sure to turn the printer power off prior to cleaning
2. Regarding print head cleaning, as the print head gets very hot during printing, turn off the printer power and wait approximately 10 minutes before commencement.
3. When cleaning the print head, take care not to touch the heated portion of the print head. The print head is subject to be damaged by static electricity.
4. Take care not to allow the print head to become scratched and/or damaged in any way.

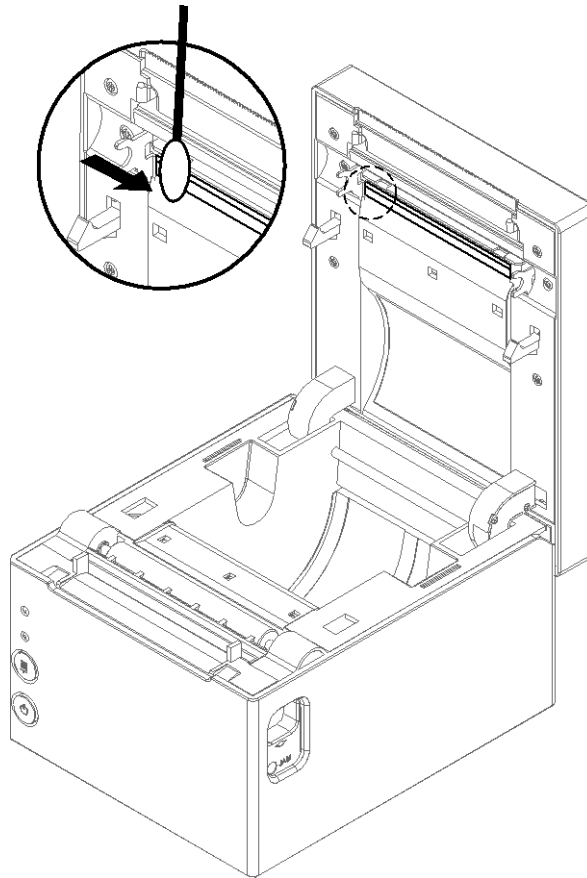

1. Use an applicator swab moistened with an alcohol solution to clean the print head and remove any dusts.
2. Once the cleaning is completed, insert paper roll into the printer a few minutes later and close the printer cover.

♣ Preventing Overheating

To prevent the motor from overheating, continuous driving of the printer should be 1.5 m or less in print length. Set the pause time for 30 seconds or more after driving the printer.

9. Specifications

9-1. General Specifications

(1) Printing Method Direct line thermal printing.

(2) Print speed 160 mm/sec. (Approx 35.4LPS)

(3) Dot density

180 DPI (Hor / Ver)	180 / 180 (0.141mm / 0.141mm dot)
---------------------	-----------------------------------

(4) Printing Width

180 DPI	Max 72mm (512 dots)
---------	---------------------

(5) Number of print columns.

No. of columns

	Font "A"	Font "B"
180 DPI	42	56

(6) Roll paper Refer to chapter 2 for details about the recommended roll Paper.

Paper width: 79.5mm ±0.5mm

Roll diameter: Max. ø83.0mm

(7) Weight 1.4Kg

(8) Overall dimension

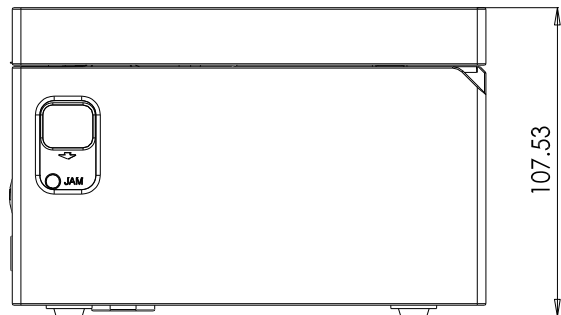
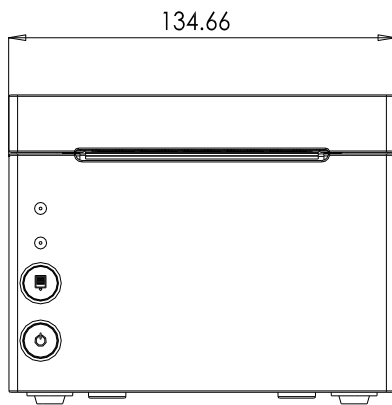
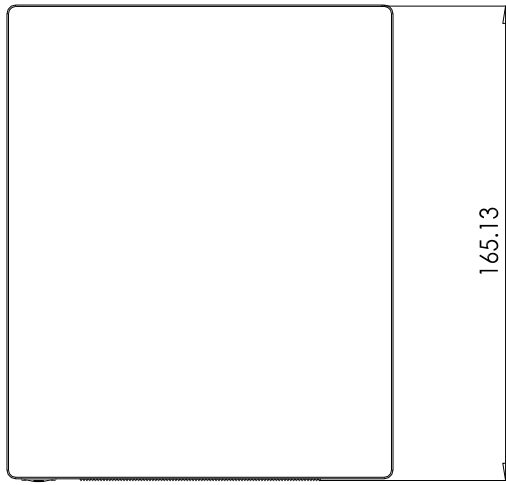

9-2. Auto Cutter Specifications

- | | |
|------------------------|--|
| (1) Cutting Frequency | Max. 30 cuts per minute |
| (2) Thickness of paper | 0.06 ~ 0.09mm |
| (3) Cutter Life | 1.5 million cuttings
(if the paper thickness is between 65 and 100 μ m) |

9-3. Interface

RS232C Serial Interface, USB Interface, Ethernet Interface(100Mbps)

9-4. Electrical Characteristics

- | | |
|-------------------------|--|
| (1) Input Voltage | DC 24V \pm 10% |
| (2) Current Consumption | Operating: Approx. 1.75 A (at ASC II printing)
Peak : Approx. 10 A
(at print duty 100%, For 10 seconds or less)
Stand-by : Approx. 0.03A(RMS) |
| (3) Power Connector | |

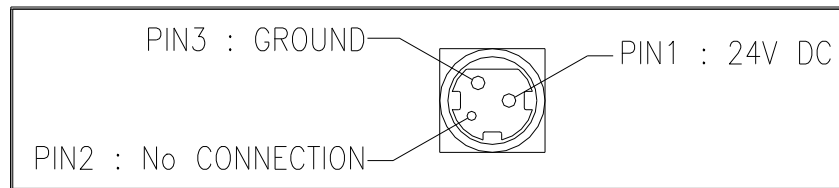

♣Important!

When using a printer power supply other than optional AC adaptor, be sure to follow below instructions.

Use a power supply (Limited Power Supply) of DC 24V±10% and more than 1.75A.

Be careful when installing the printer in an area where there is noise.

Take the appropriate measure to protect against electrostatic AC line noise, etc.

9-5. Environmental Requirements

(1)Operating

Temperature 5°C to 40°C

Humidity 10% to 90% RH (without condensation)

(2)Transport/Storage (except paper)

Temperature -20°C to 60°C

Humidity 10% to 90% RH (without condensation)

9-6. Reliability

(1)MCBF 60 million lines (based on an average printing rate of 12.5% with paper thickness in the range 65µm to 75µm)
35 million lines (based on an average printing rate of 12.5% with paper thickness in the range 76µm to 150µm)

(2)Head Life 160Km

(3)Cutter Life 1.5 million cuttings (if the paper thickness is between 65 and 90µm)

9-7. Certification

(1) FCC PART15 CLASS A

(2) CE EMCD/LVD

(CE-EMCD class B should use parallel shield cable complied with IEEE-1284 standards)

(3) UL/cUL

(4) KC

(5) ENERGY STAR

10. Command List

No.	Command	Function	REMARKS
1	HT	Horizontal tab	
2	LF	Print and line feed	
3	CR	Print and carriage return	
4	FF	Print and return to standard mode(in page mode)	
5	CAN	Cancel print data in page mode	
6	DLE EOT	Real-time status transmission	
7	DLE ENQ	Real-time request to printer	
8	DLE DC4	Generate pulse at real-time	
9	ESC FF	Print data in page mode	
10	ESC SP	Set right-side character spacing	
11	ESC !	Select print mode(s)	
12	ESC \$	Set absolute print position	
13	ESC %	Select/cancel user-defined character set	
14	ESC &	Define user-defined characters	
15	ESC *	Set bit-image mode	
16	ESC -	Turn underline mode on/off	
17	ESC 2	Select default line spacing	
18	ESC 3	Set line spacing	
19	ESC =	Select peripheral device	
20	ESC ?	Cancel user-defined characters	
21	ESC @	Initialize printer	
22	ESC D	Set horizontal tab positions	
23	ESC E	Turn emphasized mode on/off	
24	ESC G	Turn double-strike mode on/off	
25	ESC J	Print and feed paper using minimum units	
26	ESC L	Select page mode	
27	ESC M	Select character font	
28	ESC R	Select an international character set	
29	ESC S	Select standard mode	
30	ESC T	Select print direction in page mode	
31	ESC V	Turn 90° clockwise rotation mode on/off	
32	ESC W	Set printing area in page mode	
33	ESC \	Set relative print position	
34	ESC a	Select justification	
35	ESC c 3	Select paper sensor(s) to output paper-end signals	
36	ESC c 4	Select paper sensor(s) to stop printing	
37	ESC c 5	Enable/disable panel buttons	
38	ESC d	Print and feed paper <i>n</i> lines	
39	ESC p	General pulse	
40	ESC t	Select character code table	
41	ESC {	Turn upside-down printing mode on/off	
42	FS p	Print NV bit image	
43	FS q	Define NV bit image	
44	GS !	Select character size	
45	GS \$	Set absolute vertical print position in page mode	

No.	Command	Function	REMARKS
46	GS *	Define downloaded bit image	
47	GS /	Print downloaded bit image	
48	GS B	Turn white/black reverse printing mode on/off	
49	GS H	Select printing position of HRI characters	
50	GS I	Transmit printer ID	
51	GS L	Set left margin	
52	GS P	Set horizontal and vertical motion units	
53	GS V	Select cut mode and cut paper	
54	GS W	Set printing area width	
55	GS \	Set relative vertical print position in page mode	
56	GS a	Enable/disable Automatic Status Back(ASB)	
57	GS f	Select font for HRI characters	
58	GS h	Set bar code height	
59	GS k	Print bar code	
60	GS r	Transmit status	
61	GS v 0	Print raster bit image	
62	GS w	Set bar code width	
	< Add >		
1	ESC i	Full cut	
2	ESC m	Partial cut	
3	FS !	Set print mode(s) for Kanji characters	
4	FS &	Select Kanji character mode	
5	FS -	Turn underline mode on/off for Kanji character	
6	FS .	Cancel Kanji character mode	
7	FS 2 c1 d1...dk	Define user-defined Kanji characters	
8	FS C	Select Kanji character code system	
9	FS S 1 2	Set Kanji character spacing	
10	FS W	Turn quadruple-size mode on/off for Kanji character	

